

TruWave FX CANNIBAL

CONTROL DIAGRAM

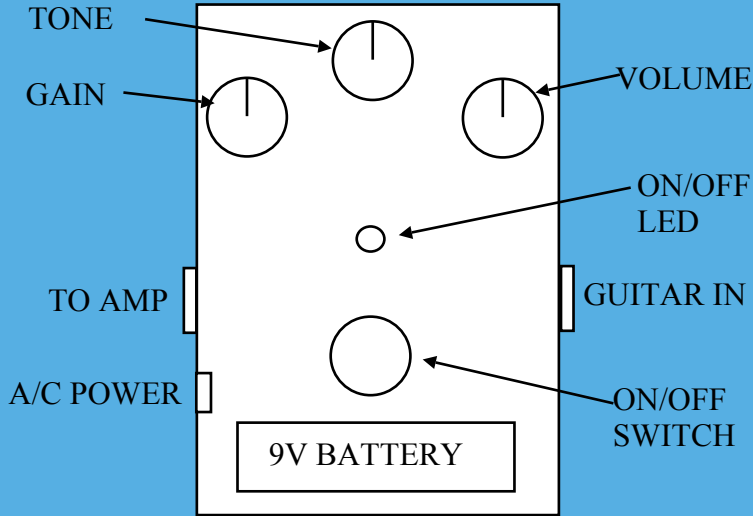

GAIN: CONTROLS A WIDE GAIN RANGE

VOLUME: CONTROLS THE VOLUME MIX

CRASH: ADJUSTS THE TONE FROM BASS (LEFT) TO TREBLE (RIGHT)

A/C POWER JACK REQUIRES 9V, 2.1mm, NEGATIVE CENTER POWER SUPPLY

REMOVE BACK PLATE TO ACCESS 9V BATTERY CLIP

TIPS FOR USING TRUWAVE FX PEDALS

TrueWave Fx pedals are unique blend of fuzz, overdrive and distortion. The product line is very diverse, therefore requires a little time to get used to. The following tips are meant to help you get the most out of these bright, innovative custom pedals.

**1.) RECOMMENDED START POSITION: LED - ON
VOLUME - 12 O'CLOCK POSITION**

GAIN - 12 O'CLOCK POSITION

TONE - 12 O'CLOCK

2.) RECOMMENDED SETTINGS:

OVERDRIVE:

GAIN - 7 O'CLOCK TONE - 1 O'CLOCK VOL - 2 O'CLOCK

MODERN DISTORTION:

GAIN - 12 O'CLOCK TONE - 3 O'CLOCK VOL - 12 O'CLOCK

EXTREME GAIN:

GAIN - 5 O'CLOCK TONE - 3 O'CLOCK VOL - 1 O'CLOCK

3.) Depending on the particular model you have chosen, you can simulate many different classical effects and come up with many unique sounds. Our pedals are also designed to blend well together, so connect two in series for awesome special effects.

HAVE FUN AND ENJOY YOUR PEDAL!