

TruWave FX WAVE DRIVER

CONTROL DIAGRAM

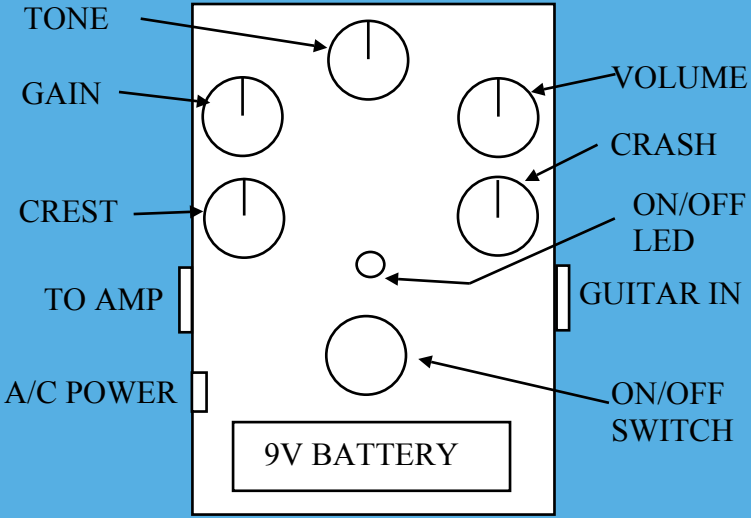

- GAIN:** CONTROLS A WIDE GAIN RANGE
- VOLUME:** CONTROLS THE VOLUME MIX
- TONE:** CONTROLS THE TONE FROM BASS (LEFT) TO TREBLE (RIGHT)
- CRASH:** ADJUSTS THE STYLE OF CLIP
- CREST:** CONTROLS THE SHAPE OF THE CLIP FROM SOFT (LEFT) TO HARD (RIGHT)
- A/C POWER JACK** REQUIRES 9V, 2.1mm, NEGATIVE CENTER POWER SUPPLY
- REMOVE BACK PLATE TO ACCESS 9V BATTERY CLIP

TIPS FOR USING TRUWAVE FX PEDALS

TrueWave Fx pedals are unique blend of fuzz, overdrive and distortion. The product line is very diverse, therefore requires a little time to get used to. The following tips are meant to help you get the most out of these bright, innovative custom pedals.

- 1) RECOMMENDED START POSITION:** LED - ON
VOLUME - 12 O'CLOCK POSITION
GAIN - 12 O'CLOCK POSITION
CRASH CONTROL - ALL THE WAY COUNTER CLOCKWISE 7 O'CLOCK POSITION
- 2.) When trying the pedal for the first time, turn the "CRASH" control all the way counter clockwise. This nulls the "CRASH" effect, and the pedals will operate in much the same fashion as other pedals. Once you hear the standard gain and typical volume effect, turn the crash control slowly clockwise for a progressively dirty, buzzy Fuzz sound.
- 3.) Depending on the particular model you have chosen, you can simulate many different classical effects and come up with many unique sounds. Our pedals are also designed to blend well together, so connect two in series for awesome special effects.

HAVE FUN AND ENJOY YOUR PEDAL!